

ULTRA HIGH TEMPERATURE SERIES WATER SOURCE HEAT PUMP



61CWD

Nominal heating capacity 110 - 540 kW

APPLICATION RANGES

- Industrial process heating
- District heating networks
- Heat source: water or brine from process heat or heat recovery

DESIGN

- Ultra-high temperature up to 120°C
- Ultra low GWP R1233zd refrigerant - A1 safety class for indoor installation
- Screw compressors specially designed for high temperatures for heavy-duty continuous use
- Cooling system with internal circuit
- Robust shell and tube heat exchangers
- High efficiency even with small delta T

AQUAFORCE



TECHNICAL INSIGHT

Compressor

CARRIER high temperature industrial heat pumps are fitted with a semi-hermetic screw compressor specially designed for use in heat pumps with high system temperatures. With a newly developed, asymmetrical high-performance profile, these twin shaft rotation displacement machines achieve the highest levels of efficiency and maximum service life in continuous use.

With no oscillating components, they operate with very low vibrations and virtually no wear. The roller bearings are specially designed for high temperatures and sized to ensure an extremely long service life.

A high degree of operational reliability is guaranteed by means of forced lubrication, and through an integral three-stage oil separator and sump heater on the pressure side. The oil heater ensures the lubricating properties of the oil even after long downtimes. A separate cooling circuit with its own oil pumps and water-cooled oil cooler ensures the required oil temperature and/or correct bearing lubrication at high operating temperatures.

The compressor casing includes a three phase asynchronous motor. The motor armature is mounted on the shaft of the main screw rotor. It is cooled with cold refrigerant vapor. The motor winding is designed especially for the specified temperature conditions. The screw compressors are fitted with part winding (PW) motors (on capacities 110 kW & 130 kW) or a star-delta circuit (on capacities from 160kW to 540 kW) to reduce the starting current.

Heat exchanger

Evaporators and condensers are used as generously sized shell and tube heat exchangers based on the counterflow principle. Shell and tube heat exchangers ensure reliability and robust operation even under difficult conditions. The design of the heat exchangers has been optimized to ensure the maximum possible transfer capacity along with the smallest possible pressure loss and minimum space requirement. The heat exchangers are not sensitive to fouling and, due to their cylindrical shape, are resistant to pressure shock. The heat exchangers are fitted with flange connections.

Refrigerant circuit/refrigerant

The refrigerant circuit is filled with a non-combustible and non-toxic safety refrigerant. The refrigerant used is CFC-free and is therefore fully futureproof. The refrigerant charge is optimized for the highest possible coefficient of performance (COP). The refrigerant circuit undergoes a pressure and leakage test using helium or forming gas.

Safety equipment

To maximize the service life of the system, particular attention has been paid to the operational reliability of the heat pump and to protecting the compressor.

Compressor protection device

CARRIER industrial heat pumps are equipped with a protection device for the screw compressor as standard. The protection device is built into the compressor connection box and is fully wired. It monitors:

- Motor and oil temperatures
- Rotational direction
- Phase failure

Additional safety equipment

- Motor protection switch for the compressor
- Overpressure safety valve in the refrigerant circuit
- High and low pressure sensors in the refrigerant circuit for electronic monitoring of the limits of use
- Oil level monitor
- Double high pressure controller
- Hot gas sensor/monitoring of compressor outlet temperature
- Flow monitor on the evaporator and condenser
- Flow switch in oil cooling circuit

Electrical cabinet

The control cabinet of the heat pump is mounted on the long side of the heat pump and contains the power and control unit. The customer receives fully wired electrical equipment that is ready for operation according to the international standard.

Designed with IP 54 protection rating. The heat pump requires a 3x400 V (without neutral conductor) and 1x230 V connections.

The power unit includes:

- Switching elements for the compressor: contactors for part winding or star/delta start
- Contactors for source and sink circulation pumps, depending on requirements of installation overcurrent protection devices, motor protection devices, lockable main switch, transformer for 24 V control circuit, control of solenoid valves and expansion valves, designated terminal strips with inputs and outputs for connection to the BMS (outputs potential-free).

TECHNICAL INSIGHT

Control unit

The hardware of the control unit includes a programmable logic controller (PLC) and a Human Machine Interface (HMI). The software for the control unit was developed especially for 61CWD and processes the necessary number of inputs and outputs for controlling the refrigerant circuit.

The control also performs all non-mechanical safety functions of the refrigerant circuit, e.g.: frost protection alarm or field rotation monitoring on the compressor motor.

The HMI has a 10" touchscreen for entering control commands, target values and parameters. For visualization of system statuses and actual values, these can be represented on a refrigerant circuit schematic on the display.

Via pop-up menus, detailed information on various components of the heat pump can be called up.

Any alarms are displayed. All measured values are continuously monitored by the control in real time. Interfaces for remote maintenance or a higher level BMS are available.

Controller functions/safety functions

- Long-term recording of operating conditions
- Hours run counter for compressor
- Monitoring of minimum compressor downtime and runtime
- Actuation of solenoid valves for output control
- Management of actuated component alarms
- Heating/cooling mode changeover

Temperature control

The heat pump can provide various temperatures at the condenser or evaporator outlet depending on demand. The following options are available for such temperature requirements:

- Fixed target value
- 0-10 V analogue input
- 4-20 mA analogue input

Operating modes

The heat pump can be used for the following operating modes:

- Heating mode with monitoring of condenser outlet temperature
- Cooling mode with monitoring of evaporator outlet temperature

Additional functions can be implemented on the control (on request):

- Power supply and actuation of the circulation pumps for heat source and/or user loop
- Buffer tank control strategy (DHW)
- Power supply and actuation of the 3-way mixing valves on the evaporator and/or condenser

Frame

Special emphasis is placed on a robust, space saving and economical design. The heat pump components are mounted on a base frame and on the shell and tube heat exchangers, where they are partly self-supporting. Rubber/metal vibration dampers matched to the weight of the heat pump reliably isolate the heat pump from the installation location and therefore prevent structure-borne noise transmission to the foundations.

PHYSICAL DATA

61CW-D : Up to 95°C Water to Water - Very High Temperature Industrial Heat Pumps

Unit		61CW-D130	61CW-D190	61CW-D240	61CW-D320	61CW-D540
Performance data⁽¹⁾						
Heating Capacity	kW	129,0	186,0	236,0	319,0	536,0
Cooling Capacity	kW	112,0	162,0	203,0	271,0	454,0
Power Consumption	W45/W85 kW	26,9	36,4	44,8	61,4	107,6
Coefficient of Performance	-	4,8	5,1	5,3	5,2	5,0
Drawn Current	A	63,9	68,3	93,4	120,6	204,2
Heating Capacity	kW	121	175	225	303	489
Cooling Capacity	kW	98	142	180	240	383
Power Consumption	W45/W95 kW	34,4	46,6	57,0	77,8	137,4
Coefficient of Performance	-	3,5	3,8	3,9	3,9	3,6
Drawn Current		71,9	81,4	108,4	140,8	245,8
Technical data						
Dimensions (LxWxH) ⁽²⁾	mm	3700 x 1400 x 1800	3700 x 1500 x 1900	4000 x 1700 x 2000	4100 x 1800 x 2000	4300 x 1900 x 2100
Weight ⁽²⁾	kg	2000	2200	2500	3200	4000
Refrigerant	-	R1233zd (GWP=4,5 following AR4, ODP=0)				
Refrigerant charge ⁽²⁾	kg	65	75	90	115	150
	teqCO ₂	0,3	0,3	0,4	0,5	0,7
Voltage / Frequency	V/Hz	400/50				
Rotor starting current PW D/DD	A	495/770	-	-	-	-
Rotor starting current Y/Δ	A	-	354/1155	453/1333	595/1802	1062/3186
Max. Operating current	A	168	225	270	400	650
Compressor						
Quantity	-	1				
Type	-	Fixed-speed screw compressor				
Evaporator						
Temperature Difference ⁽³⁾	K	5	5	5	5	5
Water flow ⁽³⁾	m ³ /h	19,5	28,2	35,3	47,1	78,9
Fluid type	-	Water				
Operating range - Inlet temperature ⁽³⁾	°C	+35/+60				
Min. operating pressure ⁽³⁾	bar	1,0				
Max. operating pressure ⁽³⁾	bar	10,0				
Condenser						
Temperature Difference ⁽³⁾	K	5	5	5	5	5
Water flow ⁽³⁾	m ³ /h	22,8	32,9	41,7	56,4	94,8
Fluid type	-	Water				
Operating range - Outlet temperature ⁽³⁾	°C	+75/+95				
Min. operating pressure ⁽³⁾	bar	2,0				
Max. operating pressure ⁽³⁾	bar	10,0				

(1) Technical data with tolerance ±10%

(2) Reference values; the main dimensions/mass depends on the operating points and the calculated heat exchangers

(3) Data at W45/W85

Pressure drop as well as the minimum and maximum flow rate of the evaporator and the condenser will be calculated customized after order intake.

PHYSICAL DATA

61CWTD : Up to 120°C Water to Water - Ultra High Temperature Industrial Heat Pumps

Unit		61CWTD110	61CWTD160	61CWTD210	61CWTD280	61CWTD430
Performance data⁽¹⁾						
Heating Capacity	kW	109,0	159,0	212,0	284,0	429,0
Cooling Capacity	kW	76,0	112,0	145,0	191,0	280,0
Power Consumption	W45/W110 kW	46,7	63,3	83,0	108,0	185,4
Coefficient of Performance	-	2,3	2,5	2,6	2,6	2,3
Drawn Current	A	86,7	104,2	134,0	177,0	315,0
Heating Capacity	kW	107	156,0	209,0	280,0	403,0
Cooling Capacity	kW	70,0	103,0	135,0	177,0	251,0
Power Consumption	W45/W118 kW	50,9	69,0	89,0	120,0	196,0
Coefficient of Performance	-	2,1	2,3	2,3	2,3	2,1
Drawn Current	A	92,2	112,4	143,1	189,7	339,7
Technical data						
Dimensions (LxWxH) ⁽²⁾	mm	3700 x 1400 x 1800	3700 x 1500 x 1900	4000 x 1700 x 2000	4100 x 1800 x 2000	4300 x 1900 x 2100
Weight ⁽²⁾	kg	2000	2200	2500	3200	4000
Refrigerant	-	R1233zd (GWP=4,5 following AR4, ODP=0)				
Refrigerant charge ⁽²⁾	kg	65	75	90	115	150
	teqCO ₂	0,3	0,3	0,4	0,5	0,7
Voltage / Frequency	V/Hz					
Rotor starting current PW D/DD	A	495/770	-	-	-	-
Rotor starting current Y/Δ	A	-	354/1155	453/1333	595/1802	1062/3186
Max. Operating current	A	168	225	270	400	650
Compressor						
Quantity		1				
Type		Fixed-speed screw compressor				
Evaporator						
Temperature Difference ⁽³⁾	K	5	5	5	5	5
Water flow ⁽³⁾	m ³ /h	13,2	19,5	25,2	33,2	48,7
Fluid type	-	Water				
Operating range - Inlet temperature ⁽³⁾	°C	+35/+60				
Min. operating pressure ⁽³⁾	bar	1,0				
Max. operating pressure ⁽³⁾	bar	10,0				
Condenser						
Temperature Difference ⁽³⁾	K	5	5	5	5	5
Water flow ⁽³⁾	m ³ /h	19,5	28,4	37,9	50,8	76,7
Fluid type	-	Water				
Operating range - Outlet temperature ⁽³⁾	°C	+75/+120				
Min. operating pressure ⁽³⁾	bar	5,0				
Max. operating pressure ⁽³⁾	bar	16,0				

(1) Performance data with tolerance ±10%

(2) Reference values; the main dimensions/mass depends on the operating points and the calculated heat exchangers

(3) Data at W45/W110

Pressure drop as well as the minimum and maximum flow rate of the evaporator and the condenser will be calculated customized after order intake.

OPERATING MAP

Operating limits

Ultra High Temperature Heat Pump with ECO Heat source water / brine

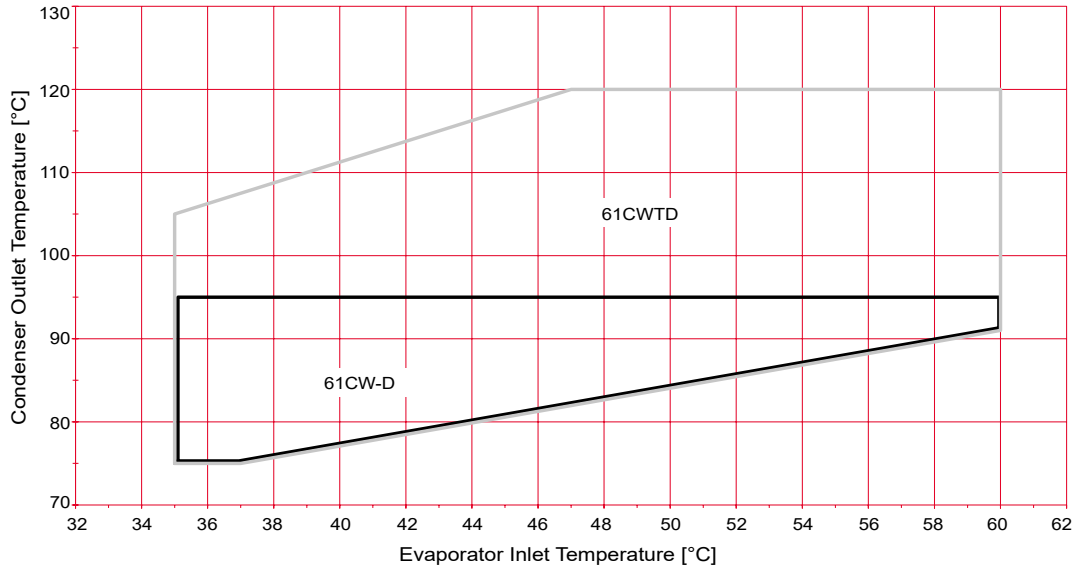

— 61CW-D
— 61CWTD
Evaporator $\Delta T=5K$
Condenser $\Delta T=5K$

The limits of use defined in the operating map above represents the switch-off values of the heat pump.
We recommend a maximum hot water set-point 2°C below the switch-off value for optimized heat pump operation.

OPTIONS

Options	N°	Description	Advantages	Aquaforce 61CW-D (up to 95°C)	Aquaforce 61CWTD (up to 120°C)
Softstarter	25	Electronic starter on each compressor	Reduced start-up current	130-540	110 - 430
Modbus interface (RS 485)	149B	Unit control compatible with the bus interface RS485 Modbus RTU. Other bus interfaces on request	The heat pump control unit with communication capability is easily integrated into the building management system	130-540	110 - 430
Gas detector (kit)	159C	Unit equipped with refrigerant leak detector Alarms are visual and acoustic. Regular checking of the gas detector is not included in the offer	Immediate customer notification of refrigerant losses to the atmosphere, allowing timely corrective actions	130-540	110 - 430
Remote access	275	The touchscreen has two 10/100 Mbit Ethernet ports (RJ45) with an integral switch. Using an Ethernet patch cable, the touchscreen can be connected to the customer company network. The operator/customer must provide a secure VPN tunnel to the customer network.	Allow remote control & Check of the unit and its operating parameters from anywhere in the world and to change/optimize any settings.	130-540	110 - 430
Sound enclosure	258	Complete enclosure for effective sound insulation of the heat pump at the installation site. Self-supporting aluminium sheet elements, filled with sound absorbing mineral wool and connected with quick-release clamps. Enclosure can be dismantled into individual parts. The individual elements have rubber elements to decouple structure-borne noise. Must be installed on a flat surface. Exclusive installation of the sound insulating enclosure at the installation site.	Sound pressure level reduction by approx. 10 -15 dB(A) Fire behaviour according to EN 13501-1: class A1, non-flammable, no flammable components.	130-540	-
Electric energy meter	294	Display of energy consumption of the unit, instantaneous (U, V, I) and cumulated (kWh) of the unit	Permits the acquisition & monitoring of energy used.	130-540	110 - 430

DIMENSIONAL DRAWINGS

61CW-D : Up to 95°C

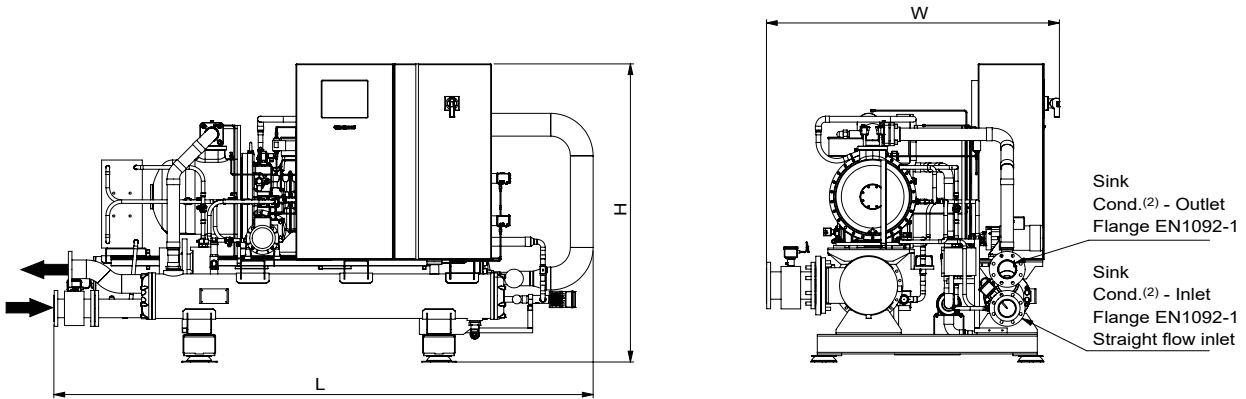

Types 61CW-D130 / 61CWD-190 / 61CW-D240 / 61CW-D320

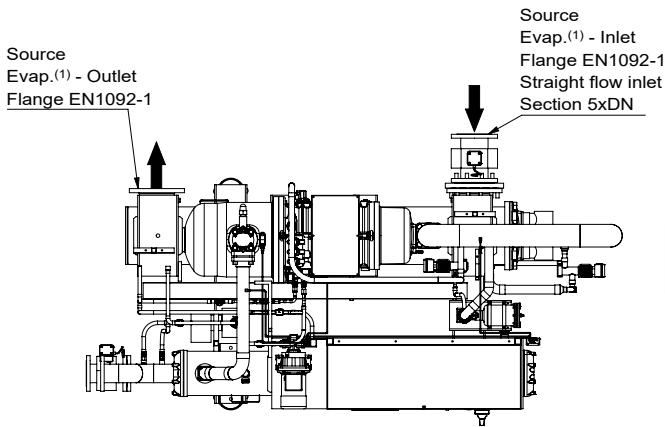

Type	L	W	H	Evap. in	Evap. out	Cond. in	Cond. out
61CW-D130	3300	1650	1800	DN100	DN100	DN65	DN65
61CW-D190	3350	1850	1800	DN150	DN200	DN100	DN100
61CW-D240	3950	1750	1800	DN150	DN200	DN100	DN100
61CW-D320	4450	2050	1900	DN150	DN200	DN100	DN125

Type 61CW-D540

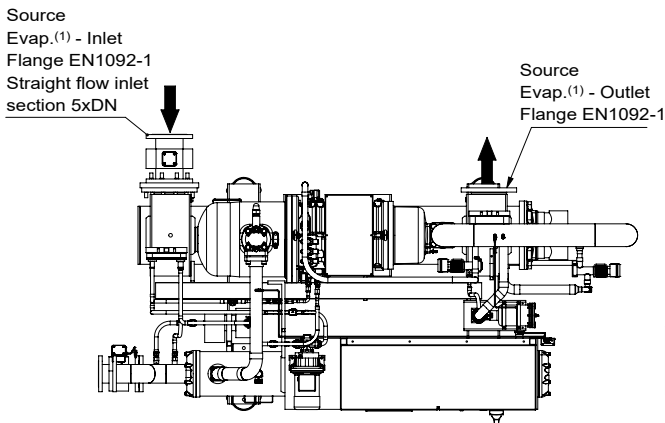

Type	L	W	H	Evap. in	Evap. out	Cond. in	Cond. out
61CW-D540	4600	2050	2000	DN150	DN200	DN150	DN150

DIMENSIONAL DRAWINGS

61CWTD : Up to 120°C

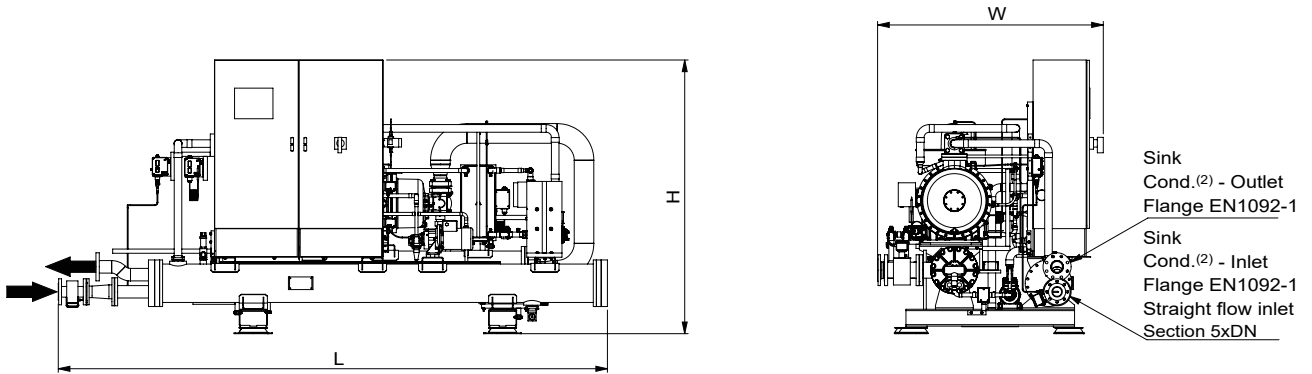

Types 61CWTD110 / 61CWTD160 / 61CWTD210 / 61CWTD280

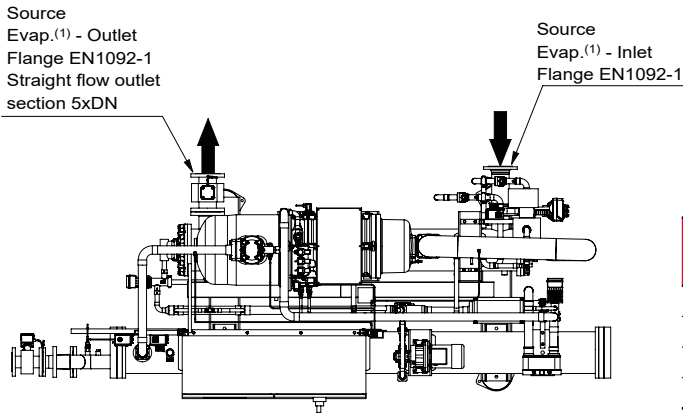

Type	L	W	H	Evap. in	Evap. out	Cond. in	Cond. out
61CW-D110	3300	1650	1800	DN100	DN100	DN65	DN65
61CW-D160	3350	1850	1800	DN150	DN150	DN100	DN100
61CW-D210	3950	1750	1800	DN150	DN150	DN100	DN100
61CW-D280	4450	2050	1900	DN150	DN150	DN100	DN125

Type 61CWTD430

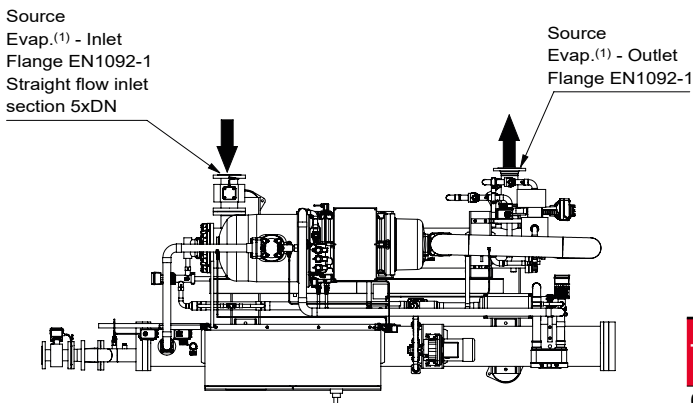

Type	L	W	H	Evap. in	Evap. out	Cond. in	Cond. out
61CW-D430	4950	2050	2000	DN150	DN150	DN150	DN150

COMPLETE CARRIER RANGES OF HIGH TEMPERATURE HEAT PUMP FOR COMMERCIAL APPLICATIONS UP TO 82°C

AquaSnap 61CG



High temperature water source heat pumps
30 to 130 kW
Hot water up to 82°C

AquaSnap 61WG



High temperature water source heat pumps
20 to 190 kW
Hot water up to 65°C

AquaSnap 61AF



High temperature air source heat pumps
22 to 105 kW
Hot water up to 65°C

COMPLETE CARRIER RANGES OF HIGH TEMPERATURE INDUSTRIAL HEAT PUMP FOR DISTRICT HEATING AND PROCESS APPLICATIONS UP TO 120°C

AQUAFORCE 61CA

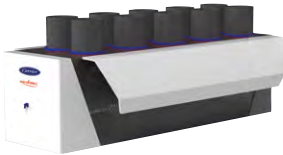

High temperature air source heat pumps
410 kW
Hot water up to 82°C

AQUAFORCE 61XWHZE



High temperature water source heat pumps
300 to 1570 kW
Hot water up to 85°C

AQUAFORCE 61CW-Z



Very high temperature water source heat pumps
410 kW to 735 kW
Hot water up to 92°C

AQUAFORCE 61CWD



Ultra high temperature water source heat pumps
110 kW to 540 kW
Hot water up to 120°C